

Zuid- Westgevel

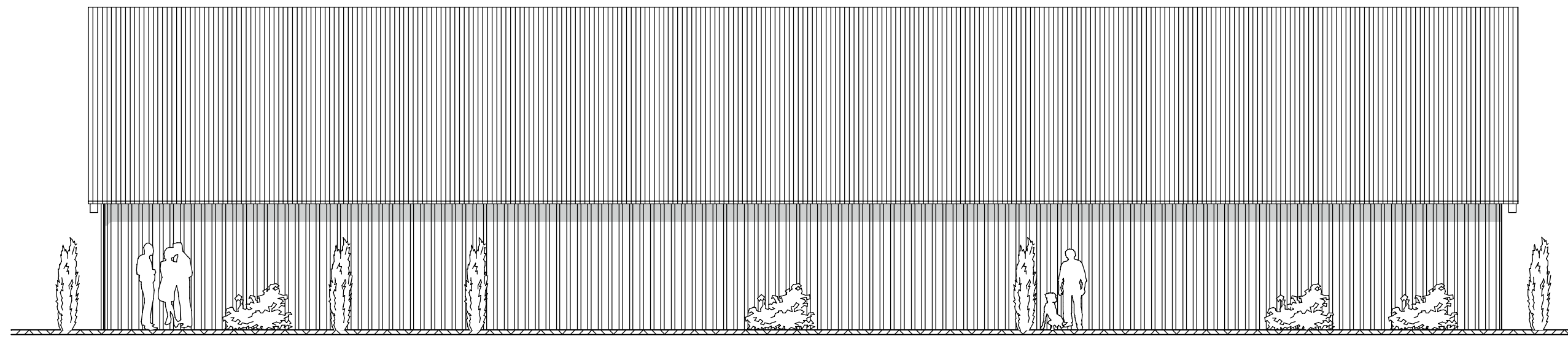

Zuid- Oostgevel

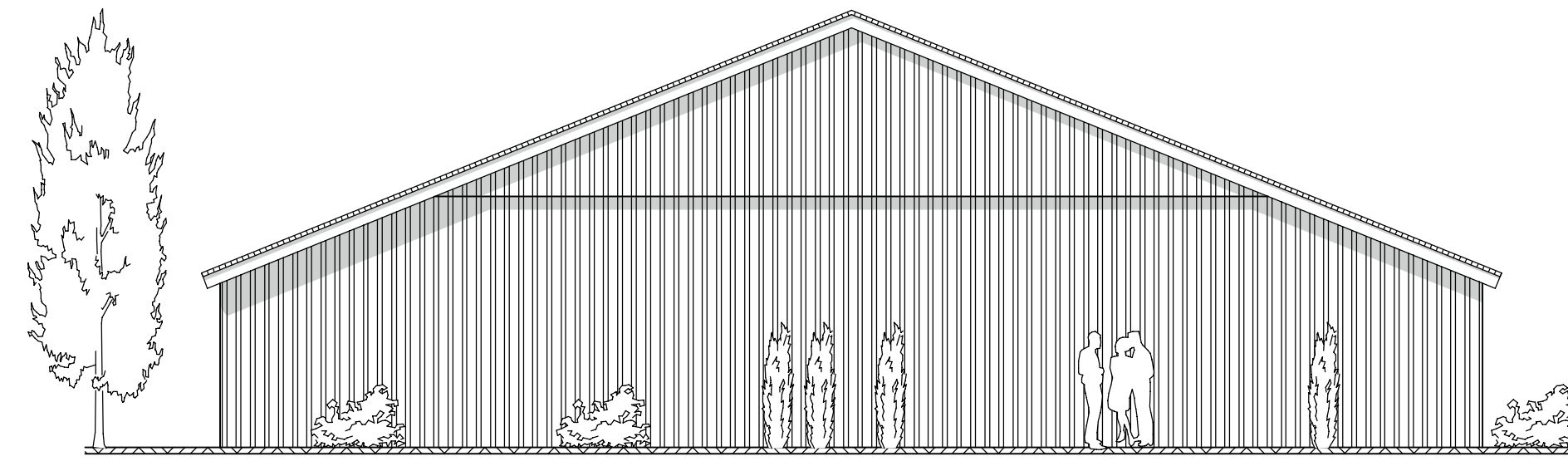

Noord- Oostgevel

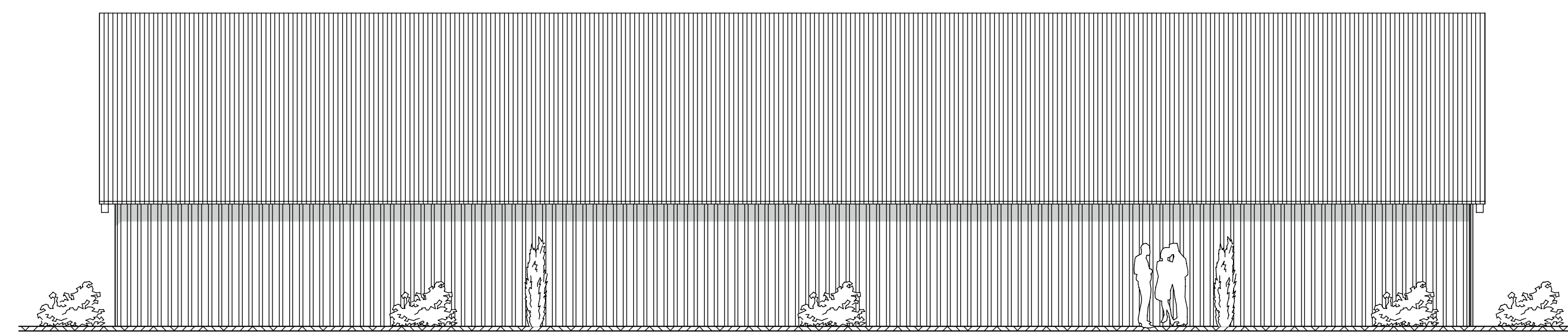

Noord- Westgevel



Algemeen

Alle maatregelen in het werk, en op besteding, te controleren en...
Alleen te bevestigen en te controleren. De afmetingen van de...

Gebouwfunctie

Industriefunctie, Lichte Industriefunctie

Materialen

Ondersteel: Materiaal: Kleur:
Dakbedekking:
Gevelbedekking:
Deuren:
Schuifdeuren:
Winkwanden / boeien:

Volume

Table with 2 columns: Bestand, Nieuwbouw, Totaal. Rows for Total floor area, Constructible area, and Total volume.

Bouwbesluit

Het bouwen zal geschieden overeenkomstig de eisen van het bouwbesluit en de gemeentelijke bouwverordening.
Detailmaten afstemmen met installateurleverancier.

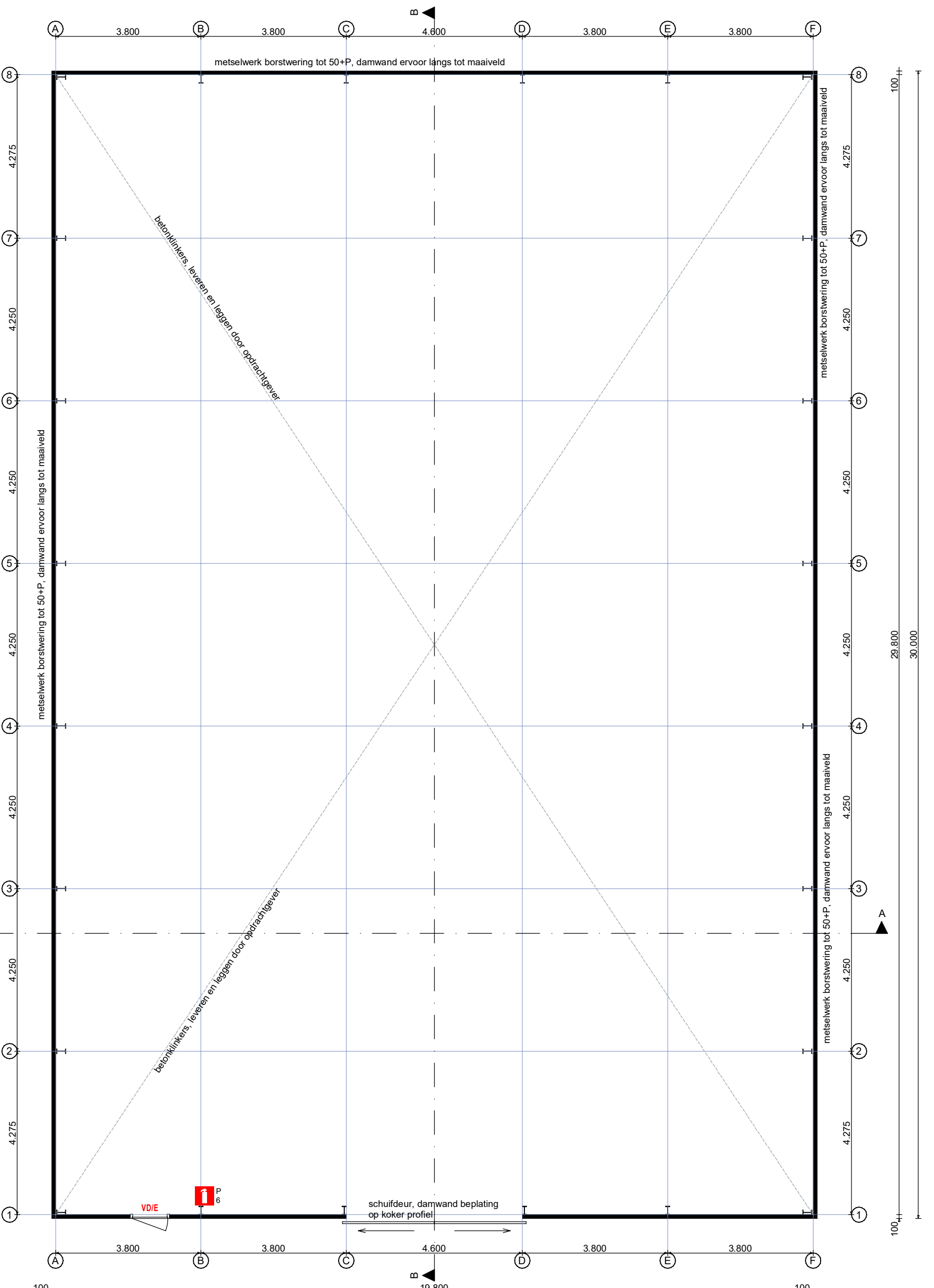

Plattegrond

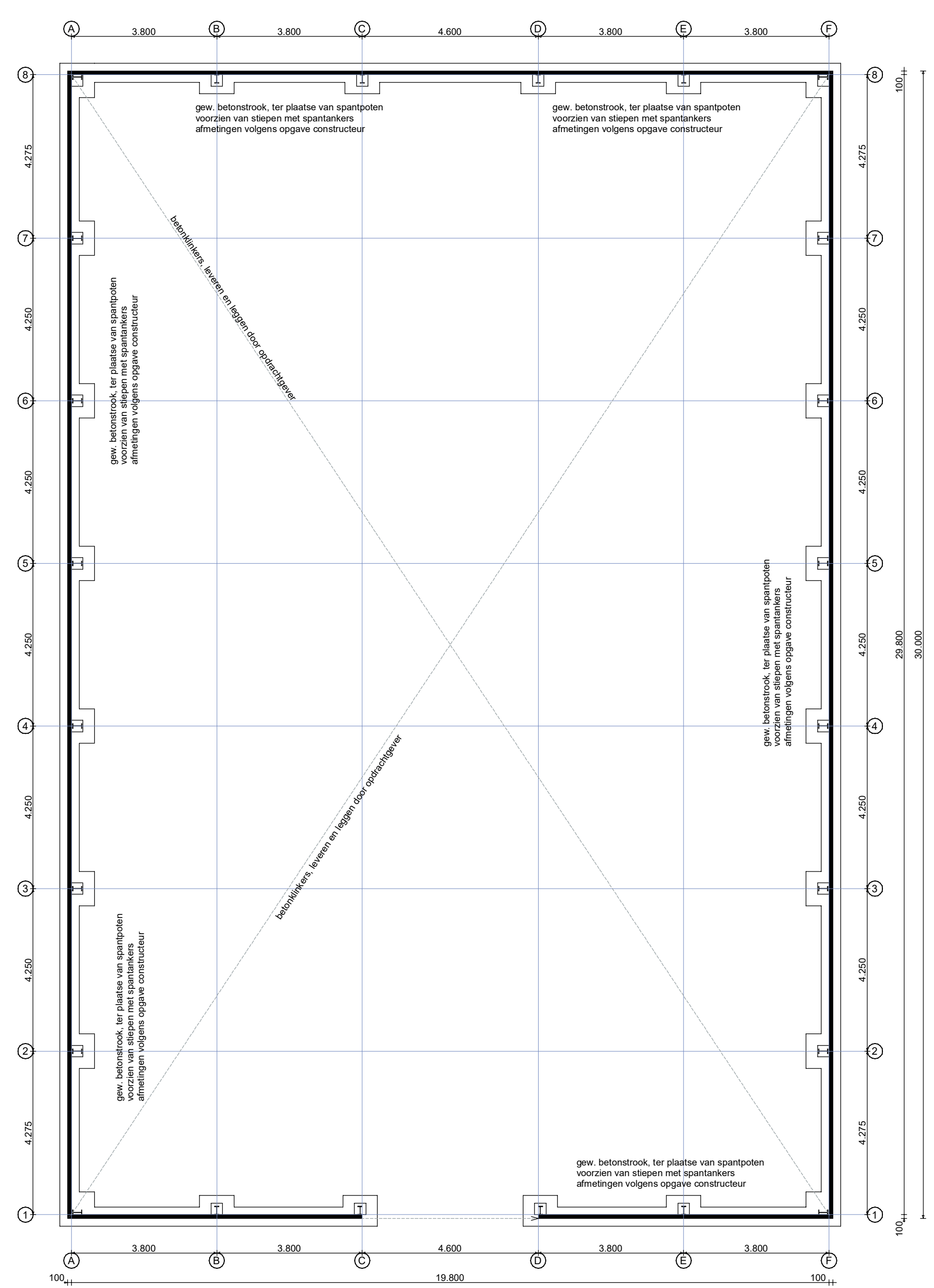

Fundering, begane grondvloer

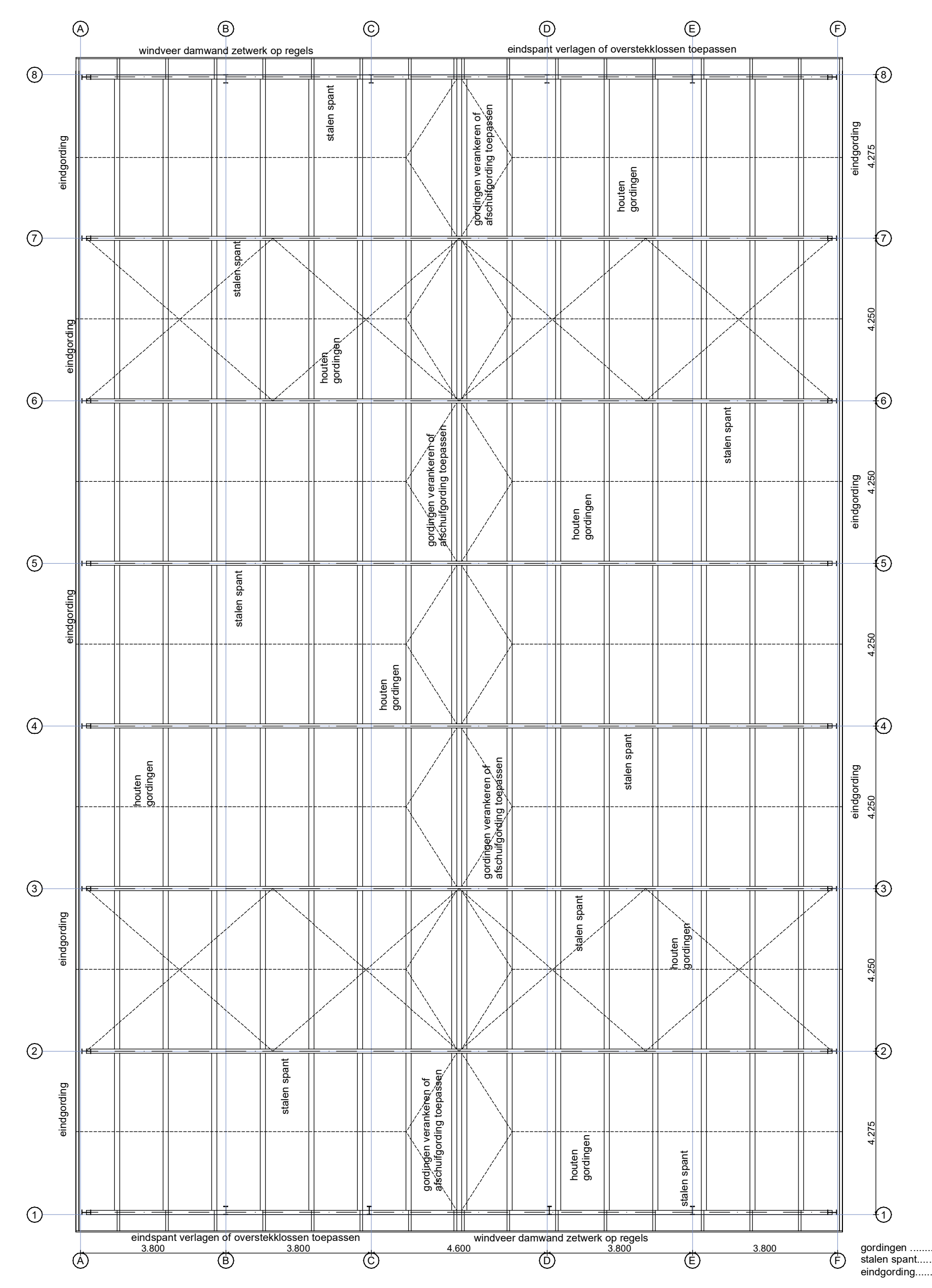

Structuurplaat

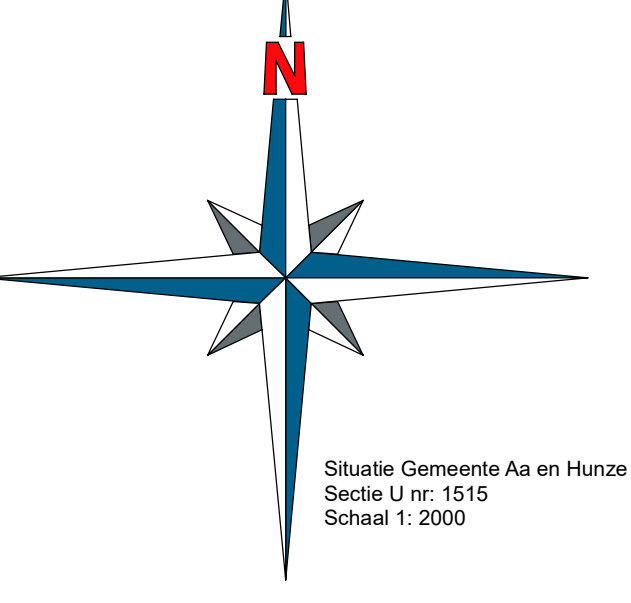

bestektekening

Datum: 22-07-2022
Revisie: A
Tekenaar: Jansman
Project:
Nieuwbouw werktuigenberging aan de Kampweg 1 te Ekehaar
Opdrachtgever:
M.T.S. ten Tije
Kampweg 1
5454 PE Ekehaar
06-14571492

Maximale opstalplaat = 34m, volgens artikel 2.102 maximaal 60m, vóórbij

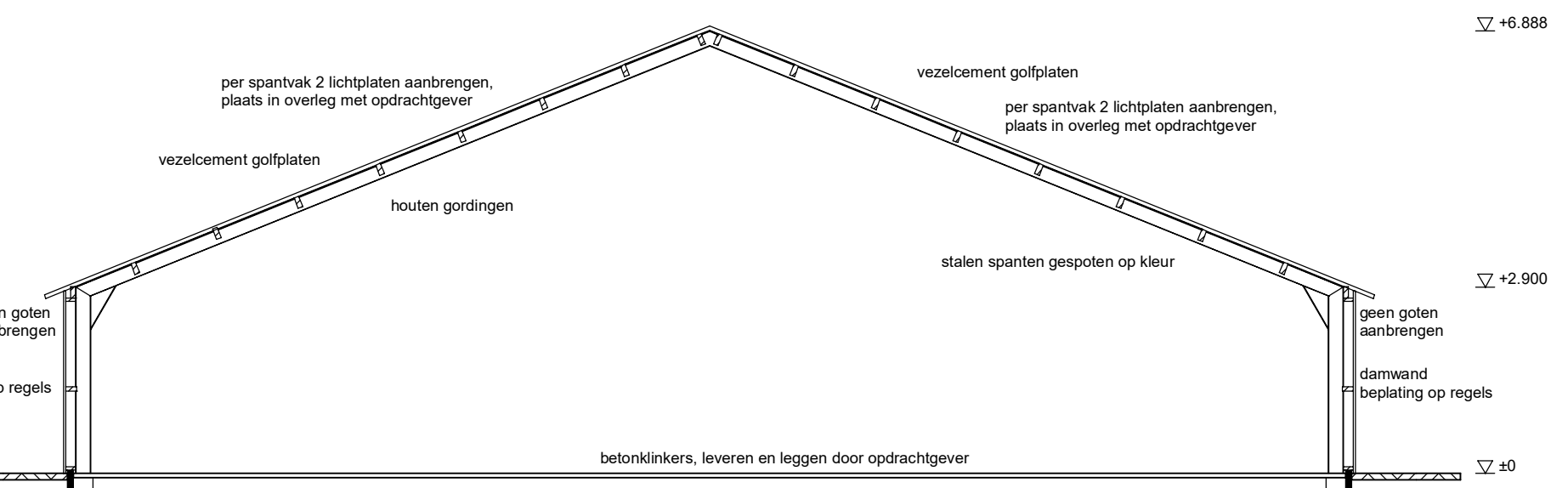

Doorsnede A-A

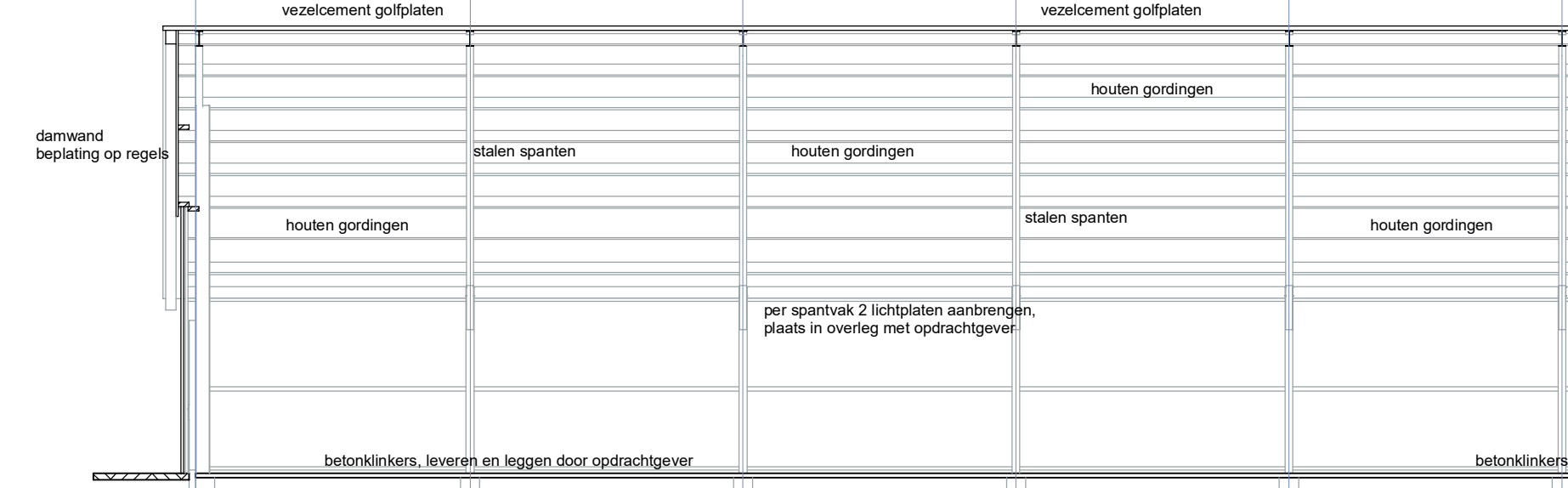

Doorsnede B-B

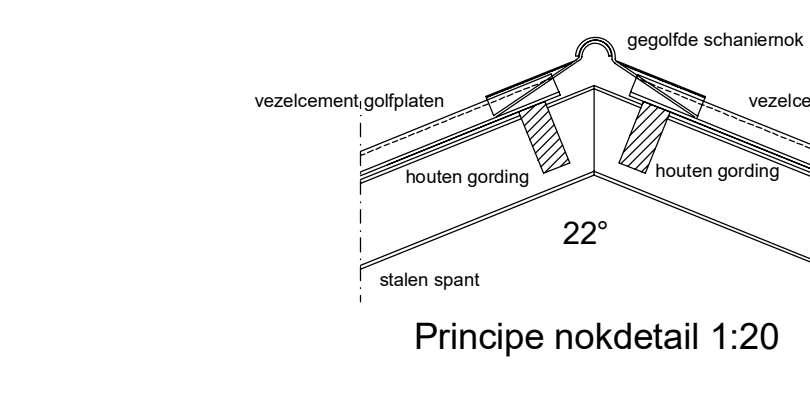

Principe nokdetail 1:20

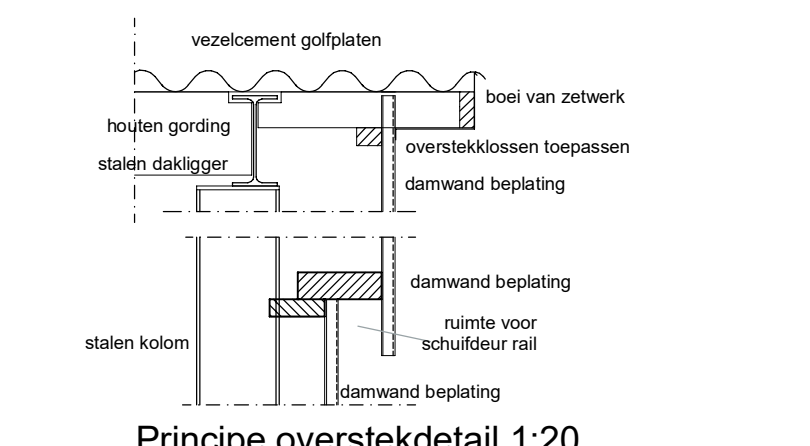

Principe overstekdetail 1:20

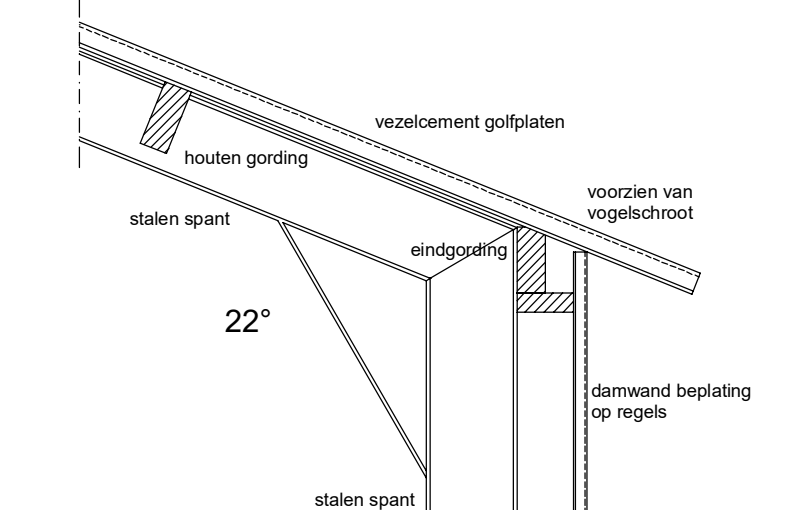

Principe gootdetail 1:20

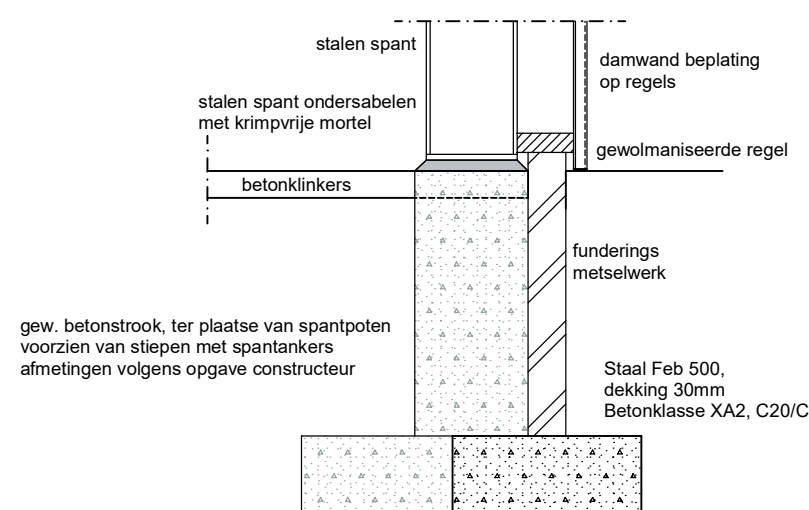

Principe funderingsdetail 1:20